

# Bucher MaxPowa V65e

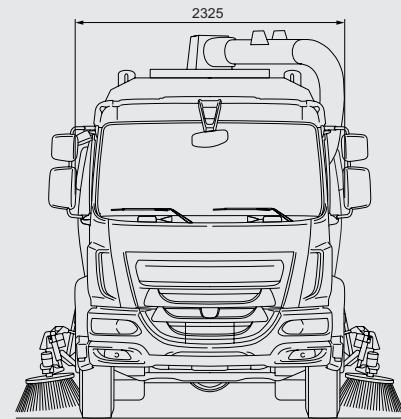
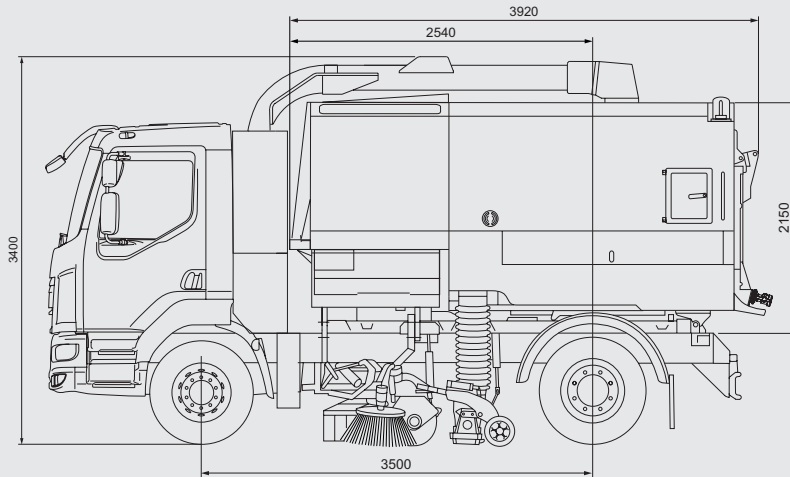

## Dimensions

Length (cowl and hopper)	3920 mm
Width	2325 mm
Height	3400 mm
Wheelbase	3500 mm
Sweeping path of suction nozzle and channel brush	1300 mm
Sweeping path with roller brush	2400 mm
Sweeping path for double-sided pick up	3600 mm

## Noise level cab

<66 dB(A) generally  
(dependent on chassis selection)

## Chassis

GVM 16 tonnes

## Battery Data

Type	Lithium-Ion Ferro Phosphate (LiFePo4)
Voltage (Nominal)	650 V
Capacity	200 kWh
Sweeping Range	up to 8 hours - EN15429-2
Transit Range	200 km

## Charging System

Charging Cycles	2000
Charging Socket	CCS (Combined charge system)
Charge Times	
AC Charging	63 A (44 kW 3 Phase) - 4 hrs 32 A (22 kW 3 Phase) - 8 hrs
DC Charging	(150 kW max) - < 2 hrs

## Features



### Charging

AC or DC charging capability with optional 32A or 63A charging cables. Onboard storage provided.



### JVM Screen

With colour 7" screen providing fault diagnosis and operational feedback and operator preferences.

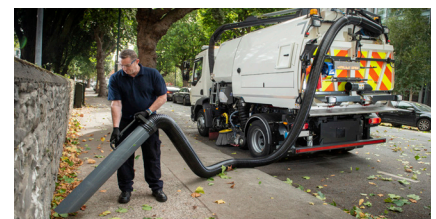

### Littasnatch

A rear lightweight rear door mounted litter hose with air operated gate for the collection of litter up to 7 metres away from the sweeper.

# Bucher MaxPowa V65e

## Controls

Centre cab mounted master control panel with JVM providing information on a wide range of sweeper functions. Up to four optional cameras can also be viewed on the JVM screen. Separate palm rest controller housing controls for the main sweeping functions is mounted on the door side.

## Exhauster fan

Operational speed variable between 1500 rpm - 3600 rpm to suit operation. Torque control feature automatically increases air power to the equivalent power of a 97 kW engine to clear blockages.

## Channel brush

Quick release brush system with infinitely variable speed up to 160 rpm (cab controlled). Hi-visibility yellow brush plate and hose guide.

## Nozzle

Cast aluminium nozzle with 250 mm diameter inlet and tool free adjustment.

## Dust suppression system

Dust suppression sprays located at suction nozzle(s), channel brush(es) and across front of vehicle. Pressadrain water purging system.

## Electrical system

650 V High Voltage System with orange high voltage cables. Fully integrated electric drive for Suction Fan (and Supawash option) with electric motor driving hydraulic motors for the sweepgear. DC charging capability (max 150 kW, recommended 100 kW for extended battery life) or an on-board 44 kW AC charger.

## Exterior noise / Sound power level

LWA 108 dB(A) measured in accordance with EC directive 2000/14/EC.

## Hopper

Body comprises of hopper & integral water tank. Fabricated from heavy duty stainless steel plate. Water tight twin lock rear door latching system with de-watering function. Two body side access doors and side storage lockers. Plug in hopper floor as transfer port for use as Streetwasher. Rear discharge chute, automatic multi position body prop, twin caged rear beacons and LED worklights are standard features.

Hopper voided volume ***	6.5 m <sup>3</sup>
Discharge angle	54° nominal
Door opening angle	125° nominal

## Water tank

Water tank incorporates anti-surge baffles and filled via a type 'A' water hydrant fill. A twin diaphragm pump runs continuously and is able to run dry.

Water capacity (Std.) 1545 l

Water capacity (Option) 2000 l

## Cowl

Smoothflow cowl lined with frequency matched soundproofing material.

## Brushes

Wide sweep brush Ø 406 mm

Width of roller brush 1275 mm

Width of suction nozzle 750 mm

Channel brush (opt. Ø 650 mm) 500mm

## Options

- Camera monitoring systems.
- AC Charging cables
- Microtrap dust suppression system.
- Powathrust/Powasave.
- Pneumatic mesh shakers.
- Powascrub - wide sweep brush ground pressure device.
- Supawash - high pressure washing system (32 l/min @ 100 bar), c/w Handlance, reel, 15m hose. Also available with nozzle spraybars.
- 6" boom mounted Wanderhose with power assist option.

\*\*\* All Bucher Municipal hopper capacities are measured in accordance with European Standard EN 15429

Your contractual partner Bucher Municipal:

**BERGOR INC. - CLEANING EQUIPMENT**  
 Administrative Office, Equipment and Parts  
 48 Rue Jean-Marc-Séguin, Rigaud, Quebec, J0P 1P0

T. 450-424-0801 TOLL-FREE 1-800-363-82  
 F. Parts 450-451-4188 F. Administration 450-451-67

www.bergor.ca - info@bergor.ca

**Driven by better**



Bucher Municipal  
E-Shop

Version 05\_04/2023  
 Technical data is subject to change without prior notice.  
 The illustrations may deviate from standard equipment.